



LS-7 Series (Plastic) Compact, Side-Mounted Level Switches

European Pressure Directive Addendum

The product is designed and manufactured in accordance with Sound Engineering Practice as defined by the Pressure Equipment Directive 97/23/EC. This product must not be used as a "safety accessory" as defined by the Pressure Equipment Directive, Article 1, Paragraph 2.1.3. The presence of a CE Mark on the unit does not relate to the Pressure Equipment Directive.

Important Points:

- | | |
|--|--|
| <ul style="list-style-type: none"> Gems products must be maintained and installed in strict accordance with the National Electrical Code and the applicable Gems product instruction Bulletin that covers installation, operation and proper maintenance. Failure to observe this information may result in serious injury or damages. For hazardous area applications involving such things as, but not limited to, ignitable mixtures, combustible dust and flammable materials, use an appropriate explosionproof enclosure or intrinsically safe interface device. Please adhere to the pressure and temperature limitations shown throughout this catalog for our level and flow sensors. These limitations must not be exceeded. These pressures and temperatures take into consideration possible system surge pressures/temperatures and their frequencies. Selection of materials for compatibility with the media is critical to the life and operation of Gems products. Take care in the proper selection of materials of construction, testing is required. | <ul style="list-style-type: none"> NSF-approved sensors are made of materials approved for potable water applications according to Standard 61. Stainless steel is generally regarded as safe by NSF and FDA. Life expectancy of switch contacts varies with application. Contact Gems if life cycle testing is required. Ambient temperature changes do affect switch set points, since the gravity of a liquid can vary with temperature. Our sensors have been designed to resist shock and vibration. However, shock and vibration should be minimized. Filter liquid media containing particulate and/or debris to ensure the proper operation of our products. Electrical entries and mounting points in an enclosed tank may require liquid/vapor sealing. Our sensors must not be field-repaired. Physical damage sustained by product may render it unserviceable. |
|--|--|

Return Policy

Returns are accepted on stock items up to 30 days from date of order. You must contact our Returns Department for a Return Authorization (RA) number. Return the goods - freight prepaid - in the original container and include original packing slip. C. O. D. returns are not accepted. Gems reserves the right to apply restocking charges.

Tel: 860-793-4357
Fax: 860-793-4563



Gems Sensors Inc.
One Cowles Road
Plainville, CT 06062-1198
Toll-Free: 1-800-378-1600

Specifications

Part Number	Mounting Type	Materials		Min. Liquid Sp. Gr.	Operating Temperature	Oper. Pres. Max. @ 70° F	Switch* SPST	Lead Wire Gauge			
		Housing and Float	Lead Wire Jacket								
76141	1	Polysulfone	PVC	.75	-40°F to +225°F(-40°C to +107.2°C)	150 psig	20 VA	#22 AWG			
76142		Ryton® R-4	Teflon®	.98	-40°F to +300°F(-40°C to +148.9°C)						
76145	2	Ryton® R-4	Teflon®	.80	-40°F to +300°F(-40°C to +148.9°C)						
76147	3	Polysulfone	PVC	.75	-40°F to +225°F(-40°C to +107.2°C)						
76148		Ryton® R-4	Teflon®	.98	-40°F to +300°F(-40°C to +148.9°C)						
165570	3N	Nylon		.65	-40°F to +250°F(-40°C to +121.1°C)				100 psig		
◆164520	3P	Polypropylene	TPE**	.55	-40°F to +225°F(-40°C to +107.2°C)						
182600	3V	Versaplast™		.80	-40°F to +250°F(-40°C to +121.1°C)						
76151	4	Ryton® R-4	Teflon®	.80	-40°F to +300°F(-40°C to +148.9°C)						
◆131100	5	Polypropylene	TPE**	.55	-40°F to +225°F(-40°C to +107.2°C)						
140620		Nylon	TPE**	.65	-40°F to +250°F(-40°C to +121.1°C)						
177100		Versaplast™	Teflon®	.80	-40°F to +300°F(-40°C to +148.9°C)						
155100	7	Polysulfone		.75	-40°F to +225°F(-40°C to +107.2°C)	150 psig					
◆160450		Polypropylene	TPE**	.55	-40°F to +225°F(-40°C to +107.2°C)						
160460		Nylon		.65	-40°F to +250°F(-40°C to +121.1°C)						
◆165800	10	Polypropylene		.55	-40°F to +225°F(-40°C to +107.2°C)	50 psig					
165900		Nylon	TPE**	.65	-40°F to +250°F(-40°C to +121.1°C)						
182700		Versaplast™		.80	-40°F to +250°F(-40°C to +121.1°C)						
191080	12	Noryl	TPE**	.80	-40°F to +225°F(-40°C to +107.2°C)	100 psig					

* See Electrical Data on back page for more information ** Thermoplastic Elastomer Zip Cord

◆ The hydrolytically stable, glass-reinforced polypropylene is UL-recognized to UL 746B, at a relative temperature index of 65 degrees C

Dimensional Data . . . (Mounting Attitude is Horizontal)

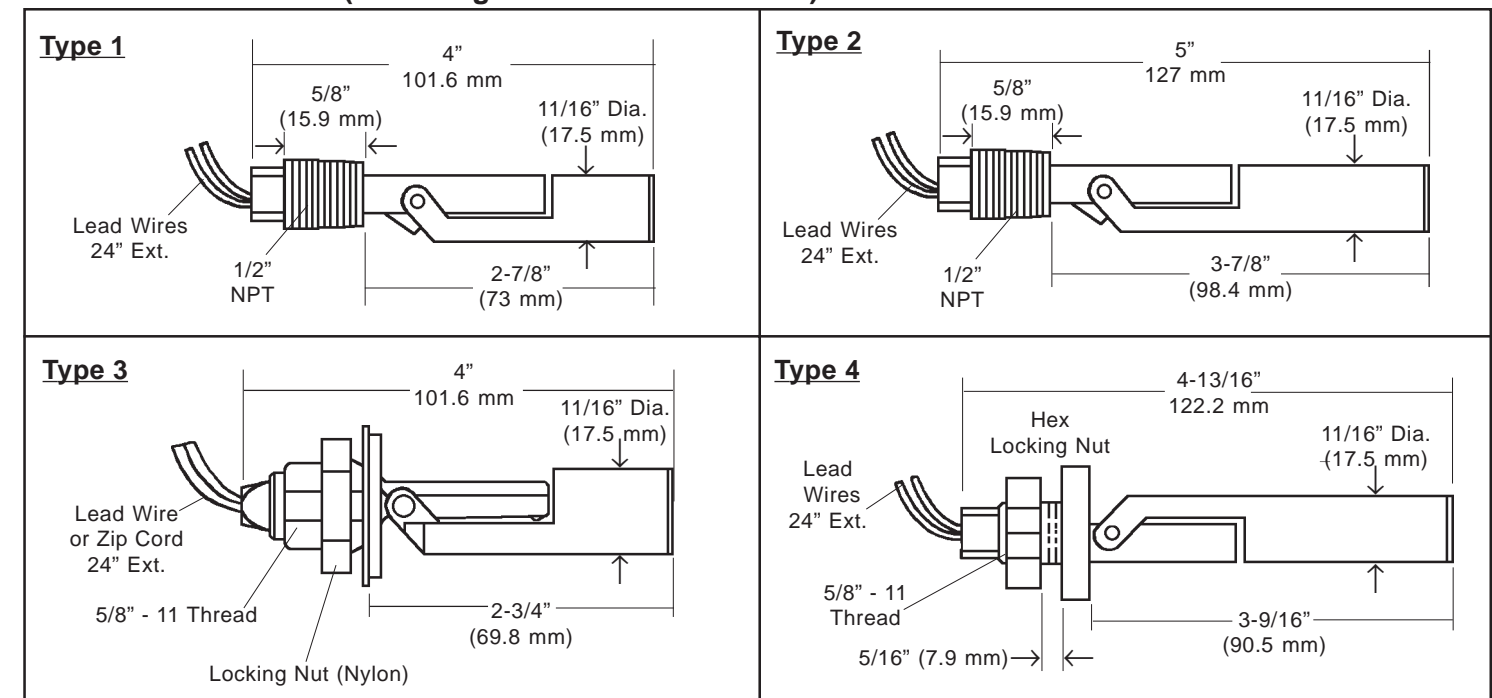

Dimensional Data (Cont.)

Type 5

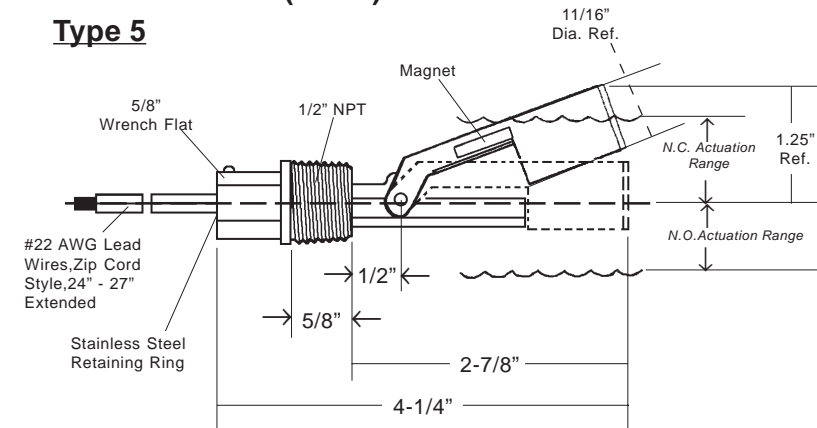

Type 7

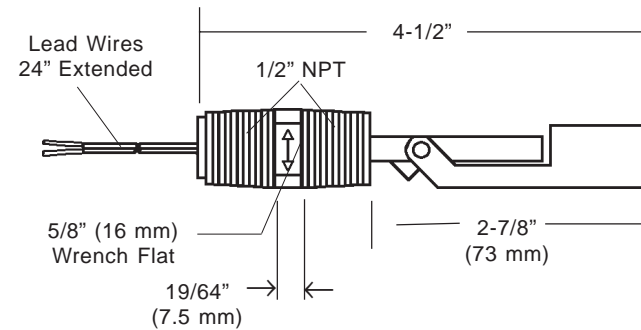

Type 10

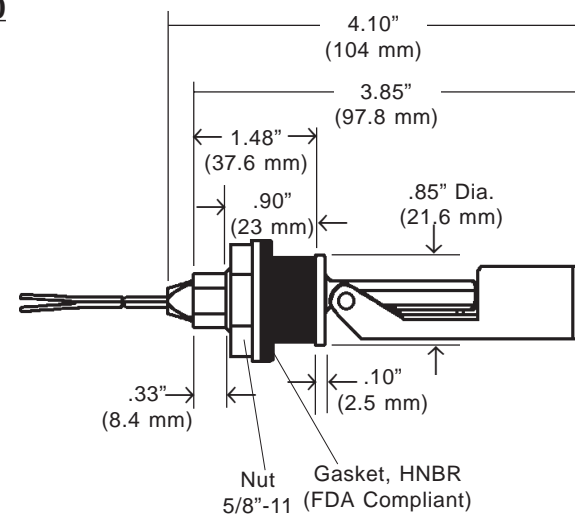

Note: Recommended hole size = 7/8" Dia. (Burr-Free)
1/32" to 3/32" tank wall

Type 12

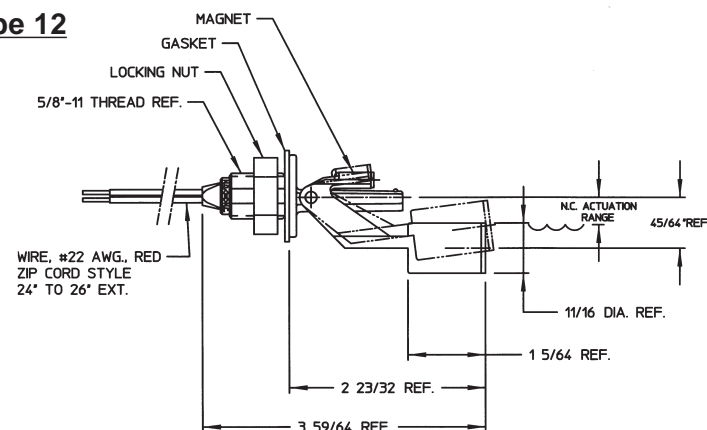

Installation

All LS-7 Units: Install with float positioned as shown for the required switch operation. Be sure that markings on wrench flats are as follows: (1) Arrow Vertical, (2) N.O. at top for N.O. operations, (3) N.C. at top for N.C. operations

Units Shown Installed "Float Down" for N.O. (Dry) Operation

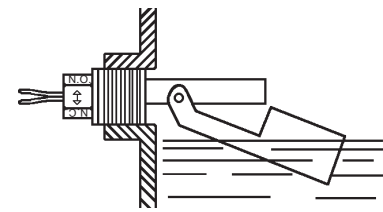

Units Shown Installed "Float Up" for N.C. (Dry) Operation

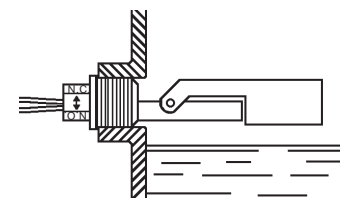

Types 3 and 4 Units

Assemble gasket (by user) on 5/8" - 11 threaded mounting and install unit through burr-free clearance hole in tank side, from inside of tank. Lock in place with HEX nut (supplied). **Tighten to 15 in./lb., Max. Do not overtighten.**

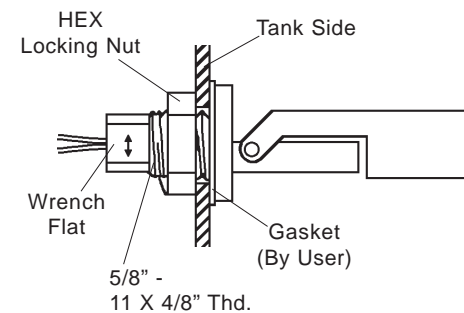

Type 10 Units

Install unit in burr-free 7/8" diameter hole in tank. Gasket flange must rest firmly against tank wall. Turn nut to compress seal. Tighten one-quarter turn past hand-tight. Use wrench flat to hold housing, if required.

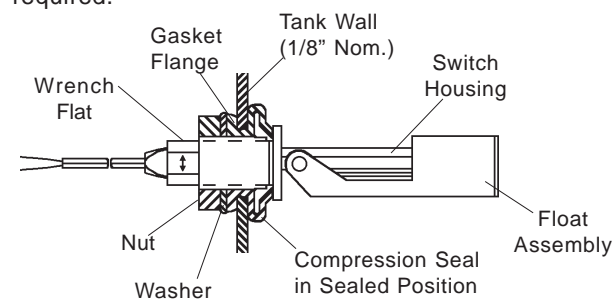

LS-7 with Compression Seal (Type 10)

Thread Treatment

Sealing: When threading metal threads into a metal coupling, pipe sealant or Teflon tape is recommended. Due to potential compatibility problems, when sealing plastic threaded units, a compatible pipe sealant such as *No More Leaks* from Permatex is recommended.

Tightening (Plastic to Metal): When threading a plastic level switch into a metal coupling, the installer should use a suitable wrench and tighten the threads 1 to 1-1/2 additional turns past hand-tight. Over-torquing of the threads will result in damage to the plastic mounting plug.

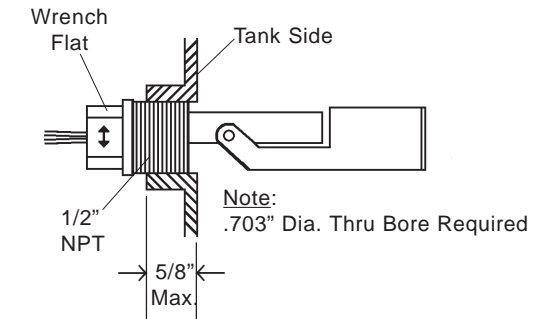

Electrical Connection

See **Typical Wiring Diagram**. Connect lead wires to load circuit, using approved method. **Caution: See "Specifications" (front page) and "Switch Ratings" (below) before connecting power.**

Typical Wiring Diagram

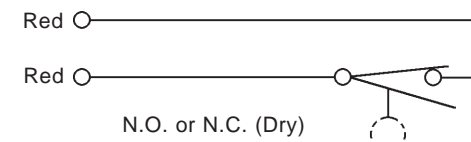

Switch Ratings - Maximum Resistive Load -

VA	Volts	Amps AC	Amps DC
20	0-30	.4	.3
Pilot Duty	120	.17	.13
	240	.080	.06

Switch Operation

Depending on the mounting position, the float on these switches can either rise or lower with the liquid level. By rotating the switch 180°, the switch operation can be Normally Open or Normally Closed. Arrows on exterior of mounting indicate N.O. when point up.

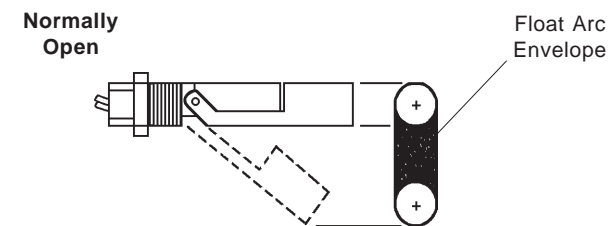

The switch is mounted so that the **float lowers** with the liquid level. **The switch is N.O.**

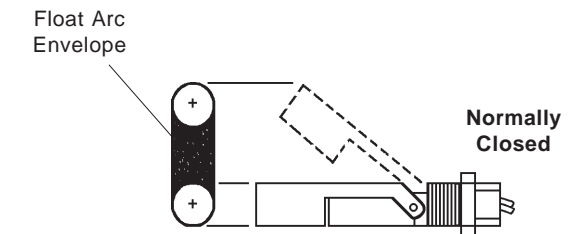

The switch is mounted so that the **float rises** with the liquid level. **The switch is N.C.**

Maintenance

Normally, no maintenance of any kind is required. When excessive contamination is present in the liquid, an occasional wipe-down cleaning is all that is needed.



This product is suitable for Class I and Class II applications only, per the requirements of standard EN60730 and any additional specific requirements for a particular application or medium being sensed. Class I compliance of metal bodied units requires a ground connection between the metal body and the earthing system of the installation. Class I compliance of plastic bodied units in contact with a conductive medium requires that the medium be effectively earthed so as to provide an earthed barrier between the unit and accessible areas. For Class III compliance, a supply at safety extra-low voltage (SELV) must be provided. Please consult the Factory for compliance information on specific part numbers.