

ENDURANCE® General Purpose Conductivity Sensors

- INITIAL CALIBRATION NOT REQUIRED.
Pre-determined cell constant ensures out-of-the box accuracy.
- VERSATILE MOUNTING CONFIGURATIONS:
screw-in, retractable, and flow-through.
- AVAILABLE WITH VARIOPOL (VP) quick disconnect fitting.

APPLICATIONS

The Model 400/400VP, 401, 402/402VP, and 404 sensors are intended for the determination of electrolytic conductivity in applications ranging from high purity water to cooling water. The sensors are ideal for use in clean, non-corrosive, samples having conductivity less than about 20,000 $\mu\text{S}/\text{cm}$. (The Model 401 sensor can be use in clean samples having conductivity as great as 200 mS/cm .) For dirty or corrosive samples or for samples having high conductivity, a toroidal sensor such as the Model 228 or 226 is recommended.

FEATURES

ENDURANCE sensors are contacting conductivity sensors. They are available in cell constants of 0.01, 0.1, 1.0, and 10/cm. The choice of cell constant depends on conductivity. High conductivity samples require larger cell constants.

Sensors with 0.01, 0.1 and 1.0/cm cell constants have concentric titanium electrodes separated by a PEEK insulator. EPDM O-rings seal the internal parts of the sensor from the process liquid. A platinum RTD in the center electrode measures the solution temperature. Electrolytic conductivity is a strong function of temperature. The temperature measurement is used for correcting the conductivity readings to a reference temperature.

Sensors with 10/cm cell constants have graphite electrodes and an epoxy body. The RTD is enclosed in a titanium capsule protruding from the end of the sensor.

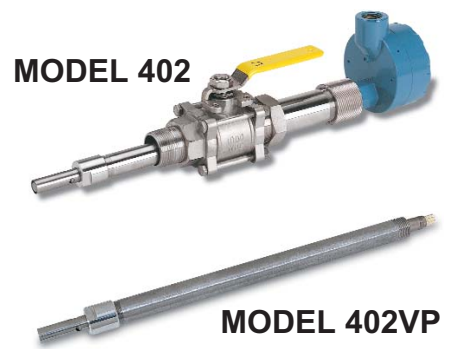

Model 400 sensors are designed for direct screw-in insertion into process piping using a 3/4-inch MNPT fitting. The Model 400 sensor can also be used in side-stream samples. A 1-inch pipe tee with a 3/4-inch bushing is a suitable flow cell. A 3/4-inch pipe tee can be used with 0.1 and 1.0/cm cells. A transparent plastic flow cell is also available (PN 24091-02).

Model 401 sensors are intended for measuring clean, non-corrosive samples having conductivity between about 500 and 200,000 $\mu\text{S}/\text{cm}$. A 10/cm two-electrode sensor (Model 401-14) and a four-electrode sensor (Model 401-15) are available. The four-electrode sensor can be used only with four electrode Solu Comp conductivity analyzers. Solu Comp analyzers are obsolete.

Model 402 sensors are retractable; they can be removed from the process piping without shutting down and draining the line. Maximum retraction pressure is 64 psig (542 kPa abs). The sensor fits through a

1-1/4 inch full-port ball valve. Order the retraction assembly, which includes the ball valve, pipe nipple, packing adapter, and clamp to position the sensor, as an option.

Model 404 sensors combine the conductivity sensor with a flow cell. The design has a small holdup volume, so response to sudden changes in process conductivity and temperature are rapid. Model 404 sensors are available with a PVC or stainless steel body. The stainless steel version can be disassembled for cleaning. The PVC version cannot be taken apart.

Models 400 and 402 sensors are available with Variopol 6.0 quick disconnect watertight connectors. Wire the interconnecting cable to the analyzer and run the cable to the sensor. The sensor plugs into the cable receptacle. To replace the sensor, simply disconnect the Variopol fitting and plug in a new sensor. There is no need to rewire or rerun cable.

SPECIFICATIONS (Models 400 and 400VP)

Cell constants: 0.01, 0.1, and 1.0/cm

Wetted materials:

Electrodes: titanium
Body: 316 stainless steel
Insulator: PEEK
O-rings: EPDM

Process connection: 3/4 inch MNPT

Temperature: 32 – 221°F (0 – 105°C)

Temperature (option -60): 32 – 392°F (0 – 200°C)

Pressure: 250 psig (1825 kPa abs) maximum

Vacuum: 7.4 psia (51 kPa abs)

Cable length (Model 400 only): 10 ft (3.1 m) standard;
50 ft (15.2 m) optional

SPECIFICATIONS (Model 401)

Cell constants: 10/cm, 0.85/cm (four-electrode)

Wetted materials:

Electrodes: graphite
Connector: PVDF (Kynar®)
Insulator and body: epoxy
O-rings: EPDM
RTD capsule: titanium

Process connection (option -14): 3/4 inch MNPT

Process connection (option -15): 1 inch MNPT

Temperature: (32 – 212°F) (0 – 100°C).

Pressure: 200 psig (1481 kPa abs) maximum

Cable length: 10 ft (3.1 m) standard; 50 ft (15.2 m)
optional

SPECIFICATIONS (Models 402 and 402VP)

Cell constants: 0.01, 0.1, 1.0, and 10/cm

Wetted materials (0.01, 0.1, and 1.0/cm cells):

Electrodes: titanium
Sensor tube: 316 stainless steel
Insulator: PEEK
O-rings: EPDM
Washer: Neoprene

Wetted materials (10/cm cell):

Electrodes: graphite embedded in epoxy body
Sensor tube: 316 stainless steel
Insulator: Epoxy
O-rings: EPDM
Washer: Neoprene
RTD capsule: titanium

Process connection: sensor is inserted through
1-1/4 inch NPT full port ball valve

Temperature: 32 – 212°F (0 – 100°C)

Pressure: 200 psig (1481 kPa abs) maximum

Retraction pressure: 64 psig (542 kPa abs) maximum

Cable length (Model 402 only): 10 ft (3.1 m).
For longer cable length, choose option -60
(integral junction box) and order interconnecting
cable separately.

¹Kynar is a registered trademark of Elf Atochem North America, Inc.

SPECIFICATIONS (Model 404)

Cell constants: 0.01 and 0.1/cm

Wetted materials (option -16):

Electrodes: titanium
 Insulator: PEEK
 O-rings: EPDM
 Body: PVC
 Fittings: polyethylene

Wetted materials (option -17):

Electrodes: titanium
 Insulator: PEEK
 O-rings: EPDM
 Body: 303 stainless steel
 Fittings: 316 stainless steel

Process connection (option -16): 3/8 inch barbed tubing connector

Process connection (option -17): compression fitting for 3/8 inch OD tubing. Fittings can be removed to leave 1/4-inch FNPT ports.

Temperature (option -16): 32 – 140°F (0 – 60°C).

Temperature (option -17): 32 – 212°F (0 – 100°C).

Pressure (option -16): 100 psig (791 kPa abs) at 77°F (25°C); 20 psig (239 kPa abs) at 140°F (60°C)

Pressure (option -17): 100 psig (791 kPa abs) maximum

Cable length: 10 ft (3.1 m) standard; 50 ft (15.2 m) optional

SPECIFICATIONS (Flow cell for Model 400/400VP, PN 24091-02)

Wetted Materials:

Body: polycarbonate
 Fittings: 316 stainless steel
 O-ring: silicone

Process connection: compression fitting for 1/4 inch OD tubing

Temperature: 122°F (50°C) maximum

Pressure: 65 psig (549 kPa abs) maximum

SPECIFICATIONS (Retraction assembly for Model 402/402VP, PN 23765-00/01)

Wetted Materials:

Ball valve: 316 stainless steel with Teflon® seals and seat steel
 Nipple: 316 stainless steel
 Packing rings: graphite
 Packing bushing 303 stainless steel
 Retraction body: 316 stainless steel

Process connection: ball valve 1-1/4 inch FNPT; nipple 1-1/4 inch MNPT

Temperature: 32 – 212°F (0 – 100°C).

Pressure: 200 psig (1481 kPa abs) maximum

Retraction pressure: 64 psig (542 kPa abs) maximum

Teflon is a registered trademark of E.I. duPont de Nemours and Co.

SENSOR AND INSTRUMENT SELECTION GUIDELINES

Instrument	Recommended for range for cell constant (µS/cm)		
	0.01/cm	0.1/cm	1.0/cm
1055	0-50	0.1-2500	10-8000
54eC	0-50	0.1-2000	10-12,000
5081-C	0-50	0.1-500	10-20,000
Xmt-C	0-50	0.1-500	10-20,000

WEIGHTS AND SHIPPING WEIGHTS

MODEL	WITH 10 ft. (3.1 m) CABLE		WITH 50 ft. CABLE		WITH JUNCTION BOX	
	Weight	Shipping Weight	Weight	Shipping Weight	Weight	Shipping Weight
400	1 lb (0.5 kg)	2 lb (1.0 kg)	4 lb (2.0 kg)	5 lb (2.5 kg)	3 lb (1.5 kg)	4 lb (2.0 kg)
401-14	1 lb (0.5 kg)	2 lb (1.0 kg)	--	--	--	--
401-15	1 lb (0.5 kg)	2 lb (1.0 kg)	4 lb (2.0 kg)	5 lb (2.5 kg)	--	--
402	3 lb (1.5 kg)	4 lb (2.0 kg)	--	--	4 lb (2.0 kg)	5 lb (2.5 kg)
404-16	2 lb (1.0 kg)	3 lb (1.5 kg)	4 lb (2.0 kg)	5 lb (2.5 kg)	--	--
404-17	4 lb (2.0 kg)	5 lb (2.5 kg)	6 lb (3.0 kg)	7 lb (3.5 kg)	--	--

MODEL	Weight	Shipping Weight
400VP	1 lb (0.5 kg)	2 lb (1.0 kg)
402VP	3 lb (1.5 kg)	4 lb (2.0 kg)

*Interconnecting cable weighs 0.6 lb/10 ft (1.0 kg/10 m).
 For shipping weight add 1 lb (0.5 kg)*

ENDURANCE SENSOR DIMENSIONS

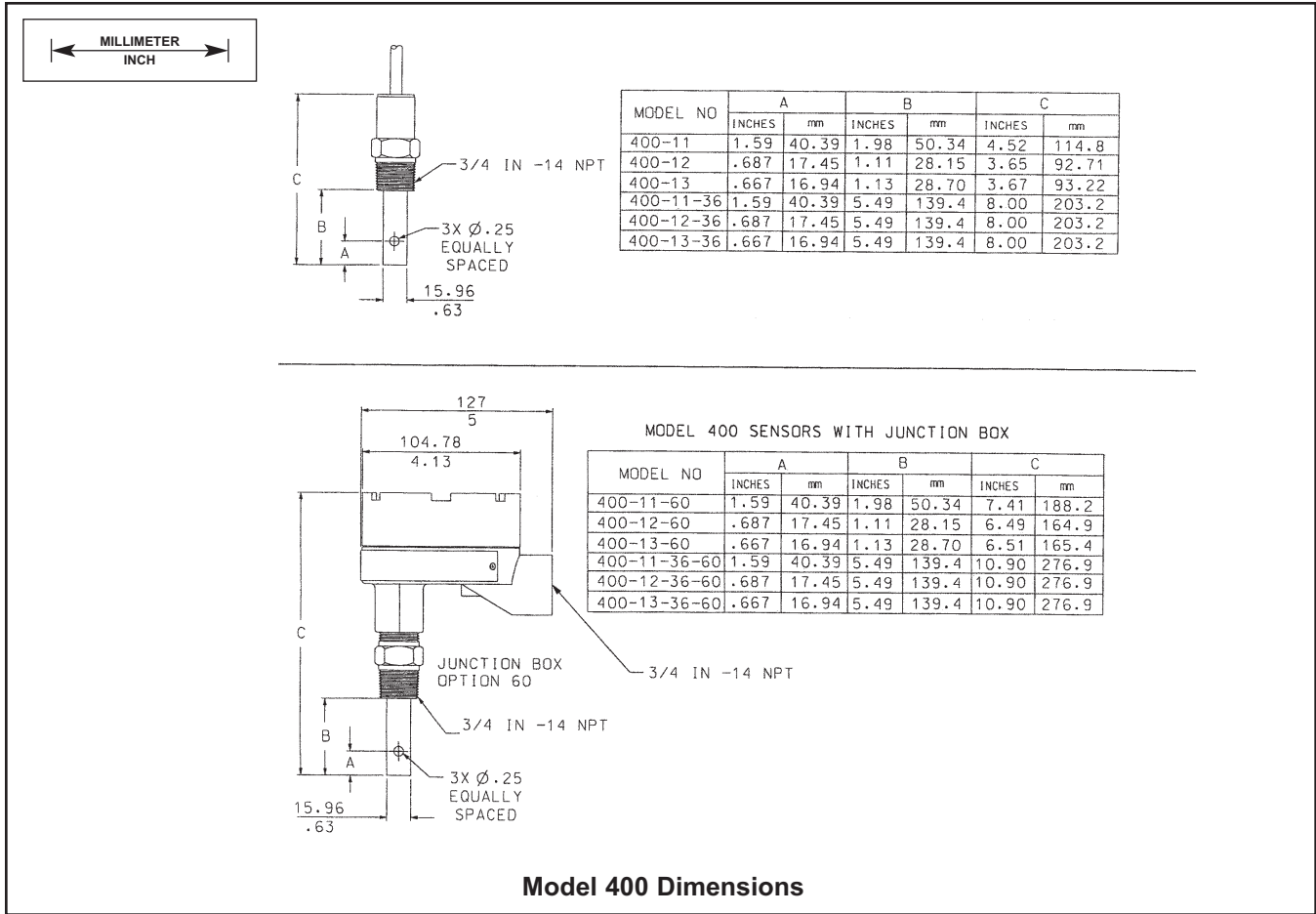

Model 400 Dimensions

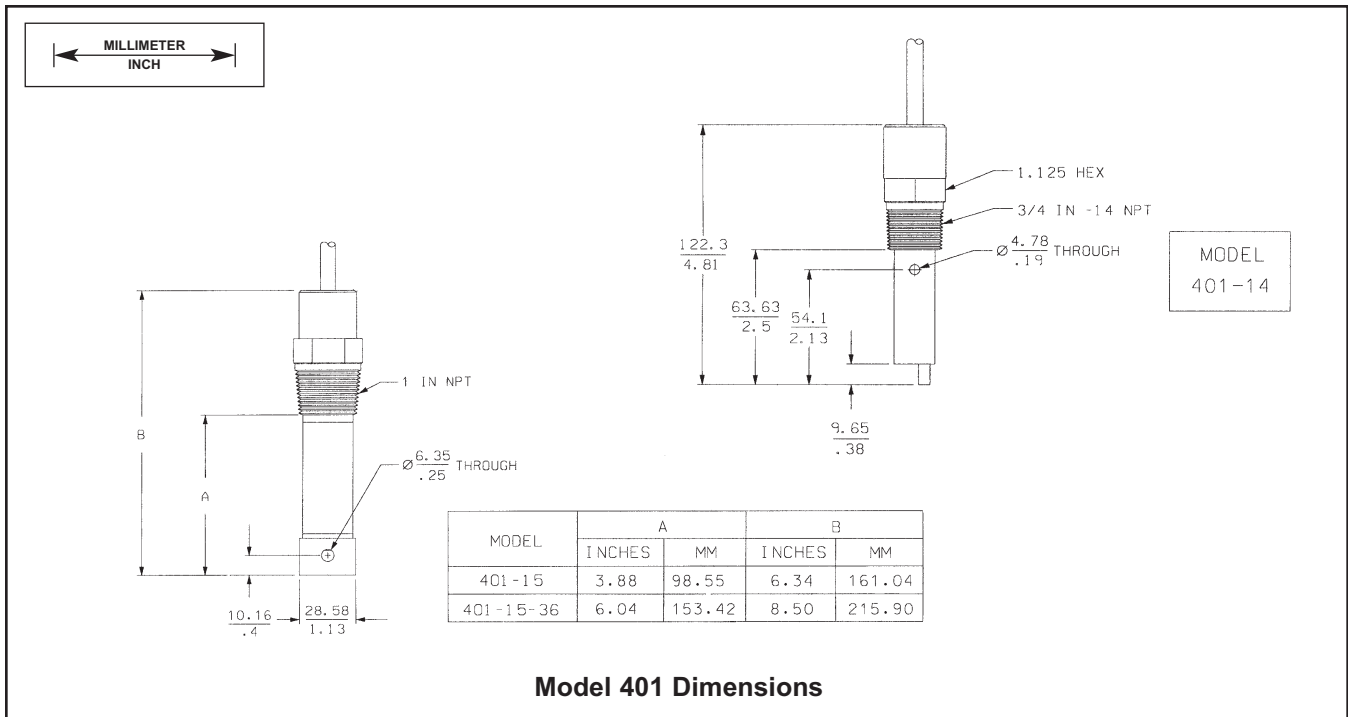

Model 401 Dimensions

ENDURANCE SENSOR DIMENSIONS

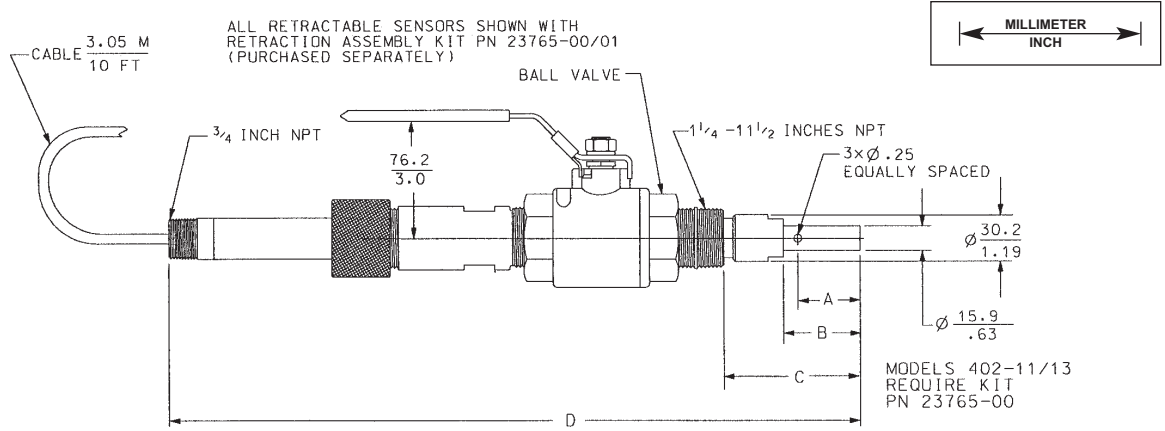

MODEL	RETRACTION ASSY KIT	A		B		C (MIN - MAX)		D	
		INCHES	mm	INCHES	mm	INCHES	mm	INCHES	mm
402-11	23765-00	1.59	40.4	1.98	50.3	3.21-5.34	82-136	18.13	460.5
402-12	23765-00	.687	17.4	1.11	28.2	2.34-4.47	59-114	17.33	440.2
402-13	23765-00	.667	16.9	1.13	28.7	2.36-4.49	60-114	17.33	440.2
402-14	23765-01	2.13	54.1	2.66	67.6	3.89-4.91	99-125	18.83	478.3

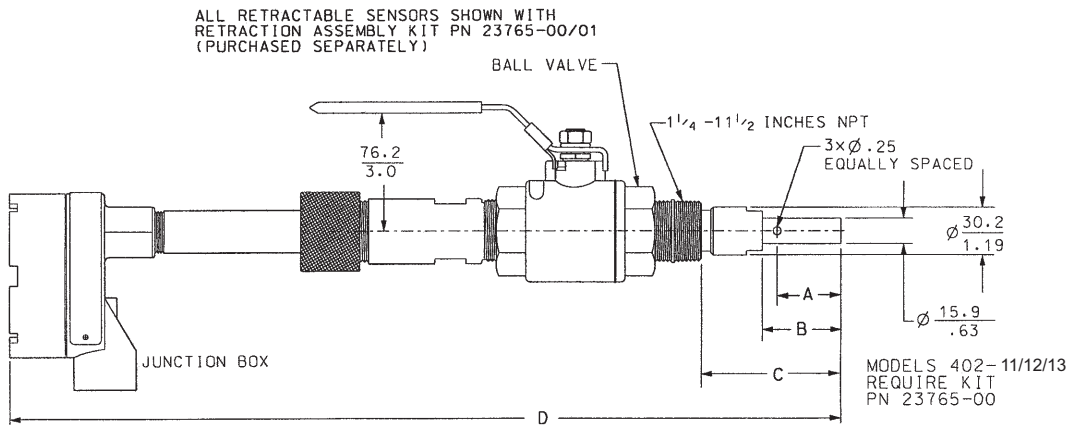
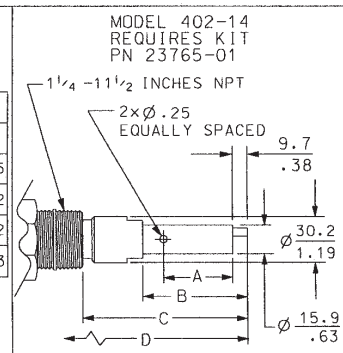

MODEL	RETRACTION ASSY KIT	A		B		C (MIN - MAX)		D	
		INCHES	mm	INCHES	mm	INCHES	mm	INCHES	mm
402-11	23765-00	1.59	40.4	1.98	50.3	3.21-5.34	82-136	21.1	537
402-12	23765-00	.687	17.4	1.11	28.2	2.34-4.47	59-114	20.3	515
402-13	23765-00	.667	16.9	1.13	28.7	2.36-4.49	60-114	20.3	515
402-14	23765-01	2.13	54.1	2.66	67.6	3.89-4.91	99-125	22.1	554

Model 402 Dimensions Shown with Options -31, -32, and -60

ENDURANCE SENSOR DIMENSIONS

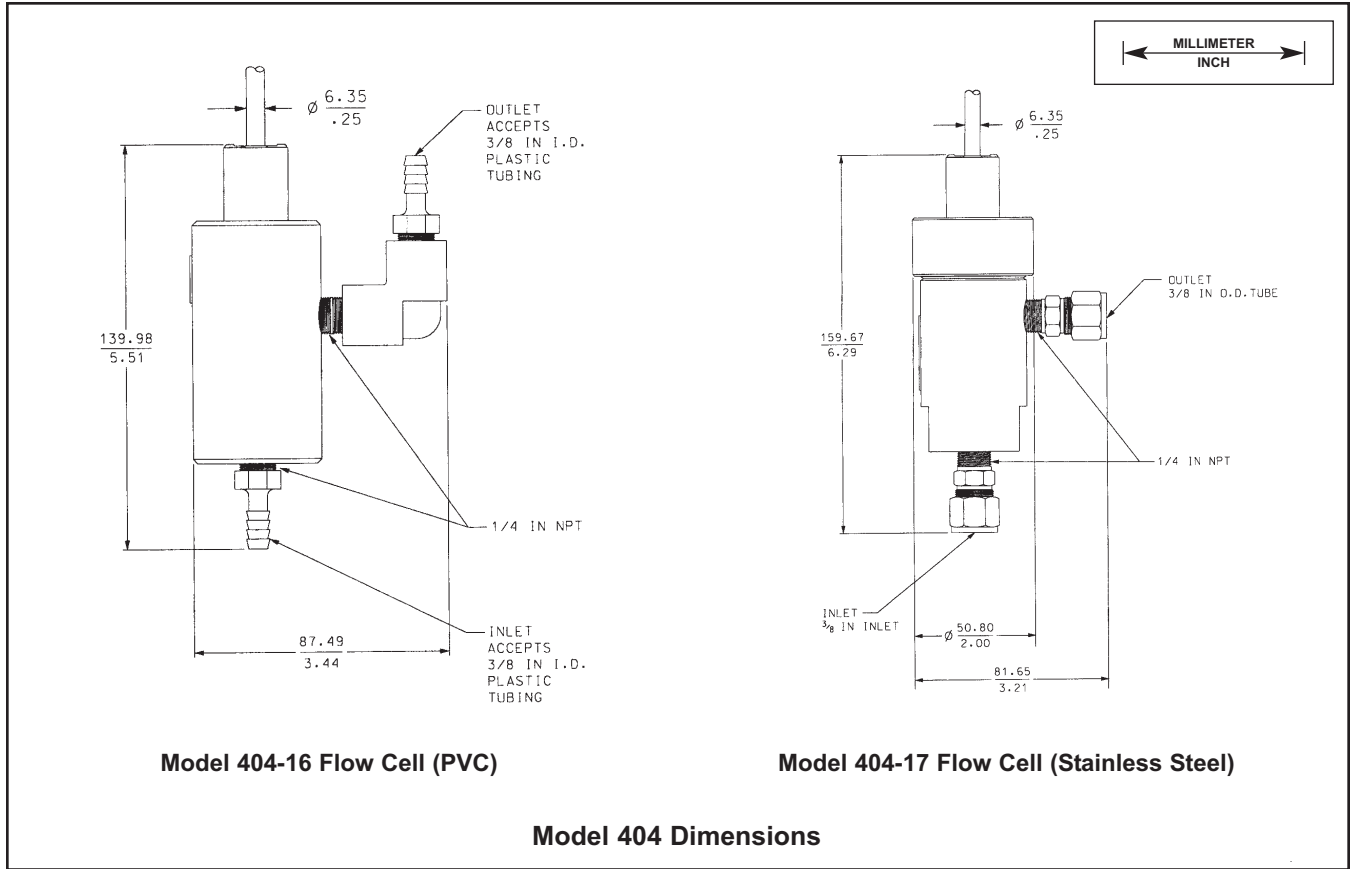

ENDURANCE SENSOR DIMENSIONS

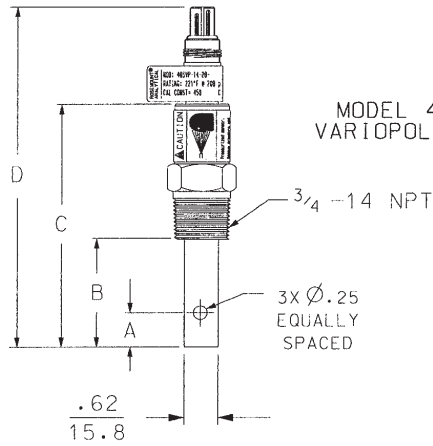

MODEL 400VP SENSOR WITH VARIOPOL (VP 6.0) CONNECTOR

MODEL NO	A		B		C		D	
	INCHES	mm	INCHES	mm	INCHES	mm	INCHES	mm
400VP-11 (-53/-54/-55/-56)	1.59	40.4	1.98	50.3	4.43	112.5	6.30	160.0
400VP-12 (-53/-54/-55/-56)	0.67	17.0	1.10	27.9	3.47	90.4	5.43	137.9
400VP-13 (-53/-54/-55/-56)	0.67	17.0	1.10	27.9	3.58	90.9	5.45	138.4
400VP-11 (-53/-54/-55/-56)-36	1.59	40.4	5.48	139.2	7.91	200.9	9.78	248.4
400VP-12 (-53/-54/-55/-56)-36	0.67	17.0	5.48	139.2	7.91	200.9	9.78	248.4
400VP-13 (-53/-54/-55/-56)-36	0.67	17.0	5.48	139.2	7.91	200.9	9.78	248.4

Model 400VP Dimensions

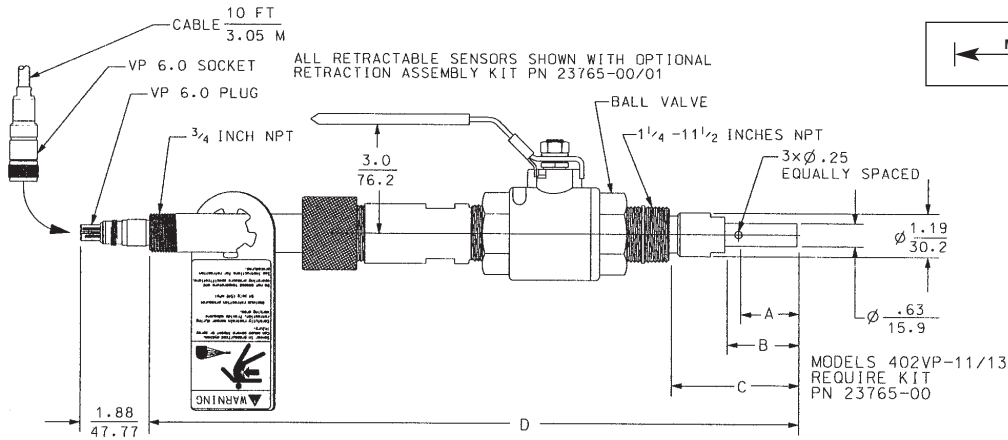

MODEL	RETRACTION ASSY KIT	A		B		C (MIN - MAX)		D	
		INCHES	mm	INCHES	mm	INCHES	mm	INCHES	mm
402-11	23765-00	1.59	40.4	1.98	50.3	3.21-5.34	82-136	18.13	460.5
402-12	23765-00	.687	17.4	1.11	28.2	2.34-4.47	59-114	17.33	440.2
402-13	23765-00	.667	16.9	1.13	28.7	2.36-4.49	60-114	17.33	440.2
402-14	23765-01	2.13	54.1	2.66	67.6	3.89-4.91	99-125	18.83	478.3

Model 402VP Dimensions

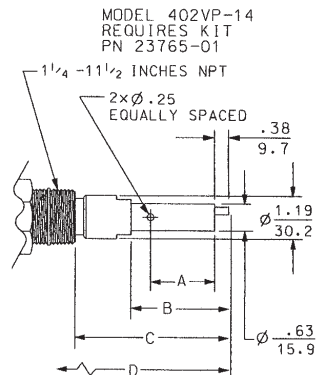

ENDURANCE INSTALLATION DETAILS

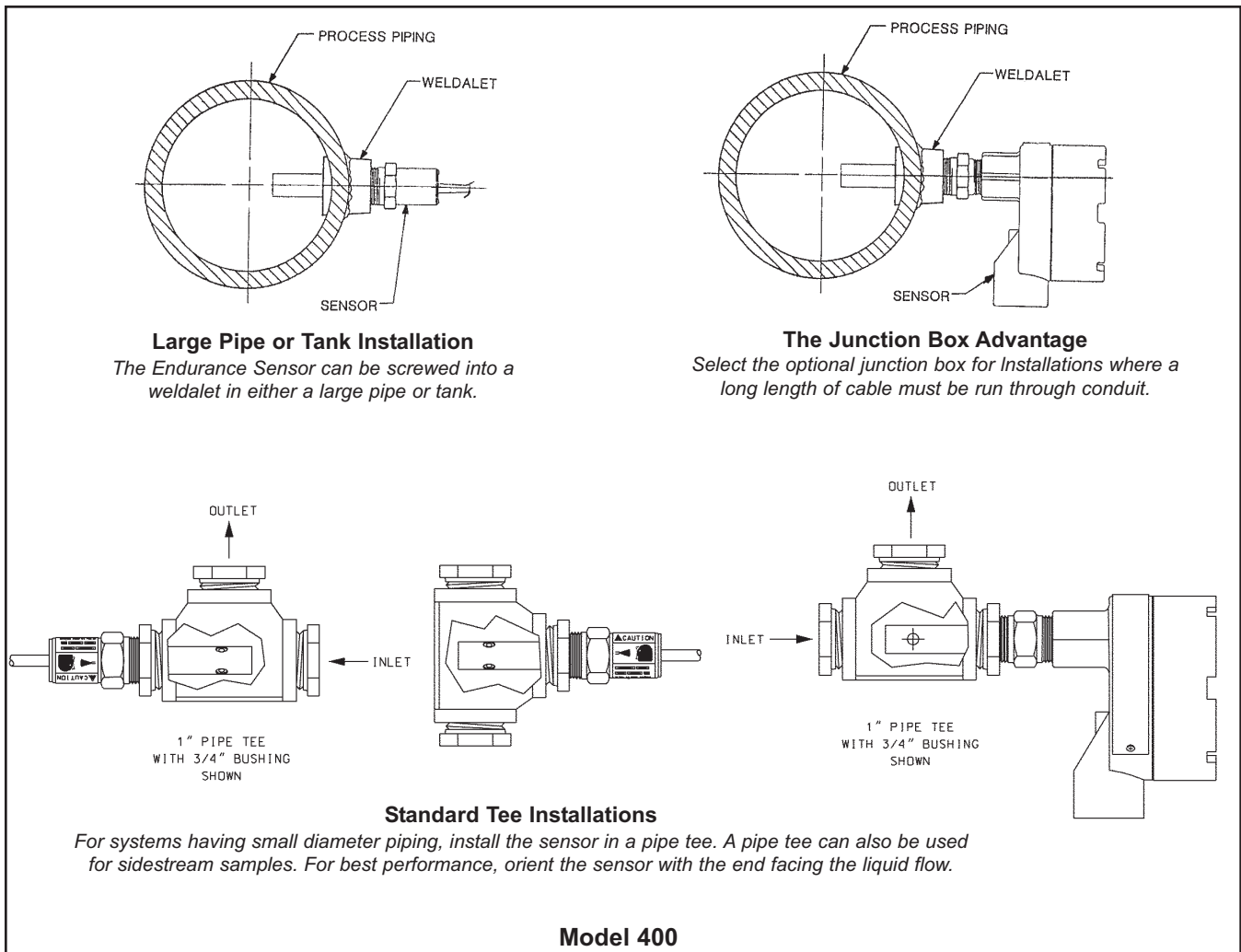
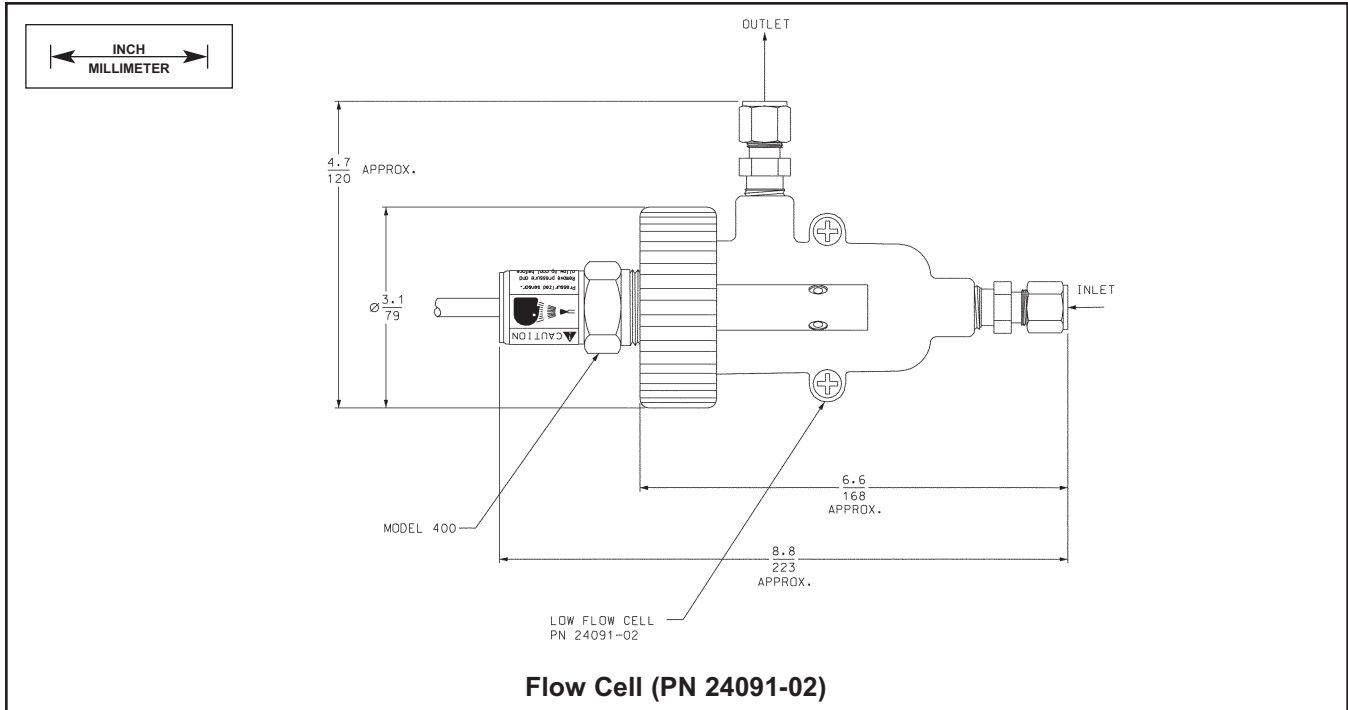

ENDURANCE INSTALLATION DETAILS

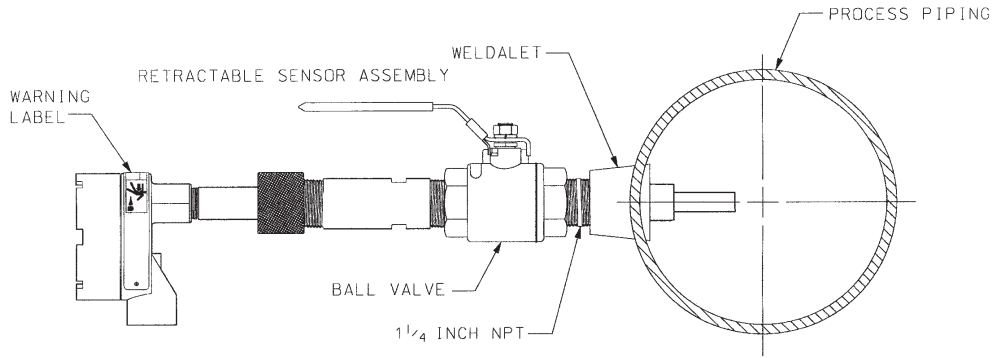

Model 402 Retractable Sensor Installed In a Large Pipe or Tank

The Endurance Retractable Sensor can be attached through a weldolet in either a large pipe or tank.

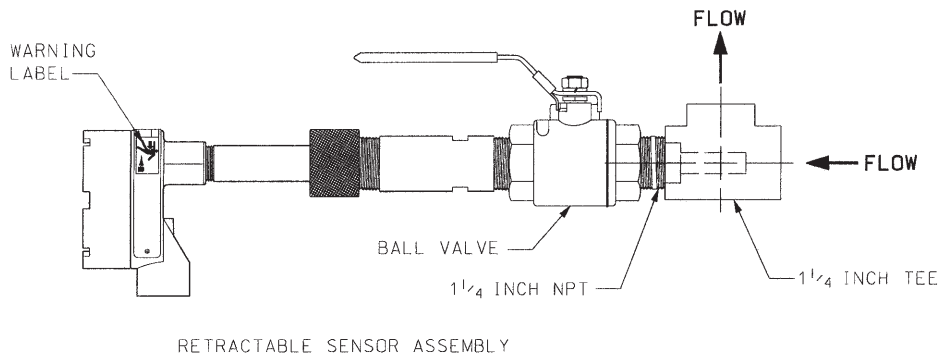

Model 402 Retractable Sensor Installed In a Standard Tee

For best performance, orient the sensor with the end facing the liquid flow.

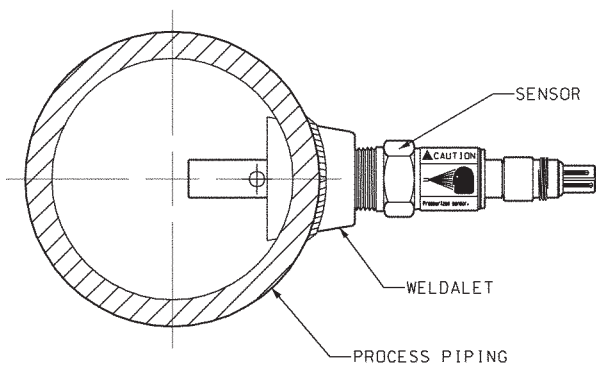

Large Pipe or Tank Installation

The Endurance Sensor can be screwed into a weldolet in either a large pipe or tank.

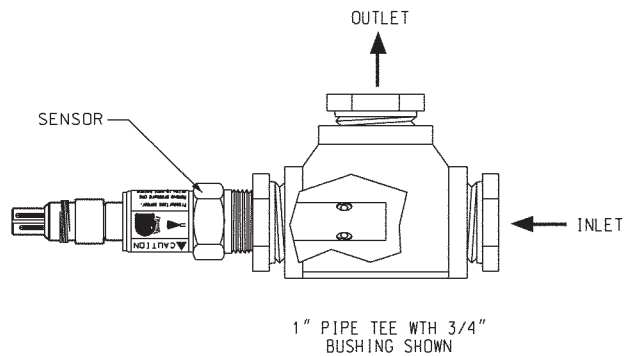

Standard Tee Installations

For systems having small diameter piping, install the sensor in a pipe tee. A pipe tee can also be used for sidestream samples. For best performance, orient the sensor with the end facing the liquid flow.

Model 400VP

ENDURANCE INSTALLATION DETAILS

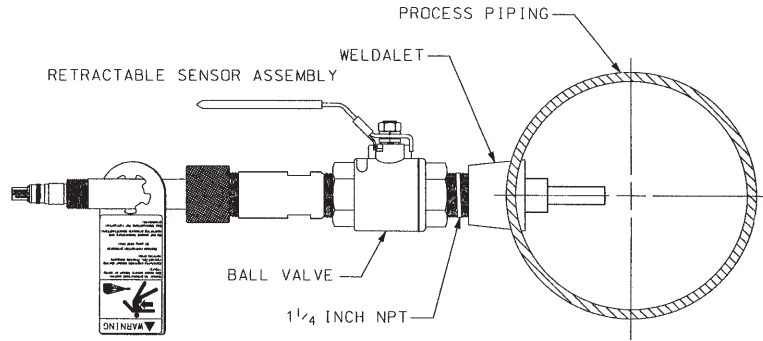

Model 402VP Retractable Sensor Installed in a Large Pipe or Tank

The ENDURANCE Retractable Sensor can be attached through a weldolet in either a large pipe or tank.

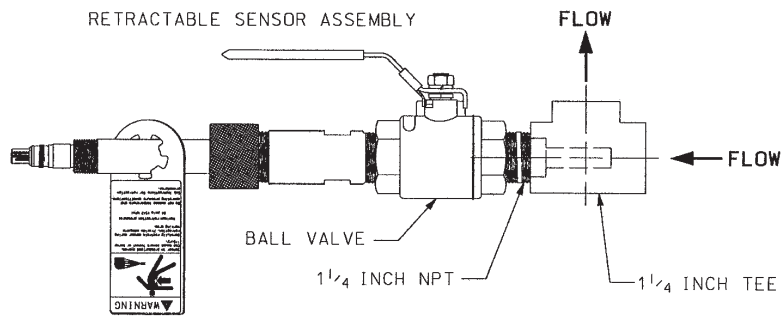

Model 402VP Retractable Sensor Installed in a Standard Tee

For best performance, orient the sensor with the end facing the liquid flow.

Model 402VP

ORDERING INFORMATION

Model 400 Screw-in conductivity sensor with integral cable is intended for the determination of electrolytic conductivity in clean water applications where the sensor can be directly screwed into the process piping or used in a pipe tee or flow cell in a sidestream.

MODEL 400 SCREW-IN CONDUCTIVITY SENSOR	
CODE	Cell Constant (required selection)
11	0.01/cm
12	0.1/cm
13	1.0/cm
CODE	Temperature Measurement
--	Pt 1000 for 1054BLC, 1054BR, 1054BDC, 1055, 54C, 54eC, 3081C, 4081C, 5081-C, and Xmt-C
54	Pt 100 for 1054C, 1054AC, 1054BC, 2081C, and 2054C
55	10K ohm TC for 1181C-08 or -10
56	100K ohm TC for 1181C-09
CODE	Additional Options (optional selection)
36	Extended insertion length (5.5 in from bottom of threads to tip of sensor)
50	Extended cable length, 50 ft (15.2 m)
60	Integral junction box (required for high temperature applications) (See NOTE.)
400	11 36 EXAMPLE

NOTE: Interconnecting cable between the junction box and analyzer must be purchased as a separate item. See **ACCESSORIES**.

ORDERING INFORMATION

Model 400VP Screw-in conductivity sensor with Variopol connector is intended for the determination of electrolytic conductivity in clean water applications where the sensor can be directly screwed into the process piping or used in a pipe tee or flow cell in a sidestream.

Interconnecting cable must be ordered separately. See ACCESSORIES.

MODEL 400VP SCREW-IN CONDUCTIVITY SENSOR	
CODE	Cell Constant (required selection)
11	0.01/cm
12	0.1/cm
13	1.0/cm
CODE	Temperature Measurement
--	Pt 1000 for 1054BLC, 1054BR, 1054BDC, 1055, 54C, 54eC, 3081C, 4081C, 5081-C, and Xmt-C
54	Pt 100 for 1054C, 1054AC, 1054BC, 2081C, and 2054C
55	10K ohm TC for 1181C-08 or -10
56	100K ohm TC for 1181C-09
CODE	Additional Options (optional selection)
36	Extended insertion length (6 in from inside face of flange to end of sensor, option -11 only)
400VP	11 EXAMPLE

Model 401 Screw-in contacting sensors for high conductivity water are intended for clean, non-corrosive samples having conductivity between about 500 and 200,000 $\mu\text{S}/\text{cm}$.

MODEL 401 SCREW-IN CONDUCTIVITY SENSOR WITH GRAPHITE ELECTRODES	
CODE	Cell Constant (required selection)
14	10/cm, 3/4 inch MNPT process connection
15	0.85/cm four electrode, 1 inch MNPT process connection for use with SCL-200 or SCL 202 only
CODE	Temperature Measurement
--	Pt 1000 for 1054BLC, 1054BR, 1054BDC, 1055, 54C, 54eC, 3081C, 4081C, 5081-C, and Xmt-C
54	Pt 100 for 1054C, 1054AC, 1054BC, 2081C, and 2054C
55	10K ohm TC for 1181C-08 or -10
56	100K ohm TC for 1181C-09
CODE	Additional Options (optional selection)
36	Extended insertion length (5.5 in from bottom of threads to tip of sensor)
50	Extended cable length, 50 ft (15.2 m)
401	14 36 EXAMPLE

Model 402 Retractable conductivity sensor with integral cable or junction box is intended for the determination of electrolytic conductivity in clean water applications where the ability to remove the sensor without shutting down the process or draining the line or tank is required.

MODEL 402 RETRACTABLE CONDUCTIVITY SENSOR	
CODE	Cell Constant (required selection)
11	0.01/cm
12	0.1/cm
13	1.0/cm
14	10/cm
CODE	Temperature Measurement
--	Pt 1000 for 1054BLC, 1054BR, 1054BDC, 1055, 54C, 54eC, 3081C, 4081C, 5081-C, and Xmt-C
54	Pt 100 for 1054C, 1054AC, 1054BC, 2081C, and 2054C
55	10K ohm TC for 1181C-08 or -10
CODE	Additional Options (optional selection)
31	Retraction assembly (complete) for options -11, -12, and -13
32	Retraction assembly (complete) for option -14 only
60	Integral junction box (See NOTE.)
61	Sensor cable terminated for use with sensor junction box (See NOTE.)
402	11 32 60 61 EXAMPLE

NOTE: Interconnecting cable between the junction box and analyzer must be purchased as a separate item. See **ACCESSORIES**.

Model 402VP Retractable conductivity sensor with VP connector is intended for the determination of electrolytic conductivity in clean water applications where the ability to remove the sensor without shutting down the process or draining the line or tank is required. **Interconnecting cable must be ordered separately. See ACCESSORIES.**

MODEL	
402VP RETRACTABLE CONDUCTIVITY SENSOR	
CODE	Cell Constant (required selection)
11	0.01/cm
12	0.1/cm
13	1.0/cm
14	10/cm
CODE	Temperature Measurement
--	Pt 1000 for 1054BLC, 1054BR, 1054BDC, 1055, 54C, 54eC, 3081C, 4081C, 5081-C, and Xmt-C
54	Pt 100 for 1054C, 1054AC, 1054BC, 2081C, and 2054C
55	10K ohm TC for 1181C-08 or -10
CODE	Additional Options (optional selection)
31	Retraction assembly (complete) for options -11, -12, and -13
32	Retraction assembly (complete) for option -14 only
402VP	12 31 EXAMPLE

Model 404 Flow through conductivity sensor is intended for the determination of electrolytic conductivity in clean water applications where rapid response to changes in conductivity or temperature is needed. The sensor must be used in a sidestream sample.

MODEL	
404 FLOW THROUGH CONDUCTIVITY SENSOR	
CODE	Cell Constant (required selection)
11	0.01/cm
12	0.1/cm
CODE	Flow Cell body
16	PVC
17	Stainless steel
CODE	Temperature Measurement
--	Pt 1000 for 1054BLC, 1054BR, 1054BDC, 1055, 54C, 54eC, 3081C, 4081C, 5081-C, and Xmt-C
54	Pt 100 for 1054C, 1054AC, 1054BC, 2081C, and 2054C
CODE	Additional Options (optional selection)
50	Extended cable length, 50 ft (15.2 m)
404	11 16 EXAMPLE

ACCESSORIES for all models

Part Number	Description	Weight	Shipping Weight
23550-00	Junction box for remote cable connection	8 lb (4.0 kg)	9 lb (4.5 kg)
9200275	Connecting cable, unterminated, specify length (not for use with 401-15 sensor)	0.6 lb/10ft (1 kg/10 m)	Add 1 lb (0.5 kg)
23747-00	Connecting cable, terminated, specify length (not for use with 401-15 sensor)	0.6 lb/10ft (1 kg/10 m)	Add 1 lb (0.5 kg)
9210004	Conductivity standard, 2,000 μ S/cm, 16 oz (0.47 L)	2 lb (1.0 kg)	3 lb (1.5 kg)
SS-6	Conductivity standard, 200 μ S/cm, 32 oz (0.95 L)	3 lb (1.5 kg)	4 lb (2.0 kg)
SS-6A	Conductivity standard, 200 μ S/cm, 1 gal (3.78 L)	9 lb (4.5 kg)	10 lb (4.5 kg)

ACCESSORIES for Model 400 and 400VP

Part Number	Description	Weight	Shipping Weight
24091-02	Flow cell, accepts sensor with 3/4-inch MNPT	1 lb (0.5 kg)	2 lb (1.0 kg)

ACCESSORIES for Model 401

Part Number	Description	Weight	Shipping Weight
661-898540	Extension cable for model 401-15	0.6 lb/10ft (1 kg/10 m)	Add 1 lb (0.5 kg)

ACCESSORIES for Model 402 and 402VP

Part Number	Description	Weight	Shipping Weight
23765-00	Retraction assembly kit (complete) for use with options -11, -12, and -13	8 lb (4.0 kg)	9 lb (4.5 kg)
23765-01	Retraction assembly kit (complete) for use with option -14	8 lb (4.0 kg)	9 lb (4.5 kg)
23796-00	Packing adapter subassembly for options -11, -12, and -13 (excludes ball valve and nipple, see figure on page 5 and 9).	4 lb (2 kg)	5 lb (2.5 kg)
23796-01	Packing adapter subassembly for options -11, -12, and -13 (excludes ball valve and nipple, see figure on page 5 and 9).	4 lb (2 kg)	5 lb (2.5 kg)
9340078	1.1/4 inch NPT full port ball valve	4 lb (2 kg)	5 lb (2.5 kg)
9160410	Packing rings for use packing adapter subassembly (PN 23796-00/01) and retraction assembly kit (PN 23765-00/01)	1 lb (0.5 kg)	2 lb (1.0 kg)

INTERCONNECTING CABLE for 400VP and 402VP sensor

Part Number	Description	Weight	Shipping Weight
23747-02	Interconnecting cable 10 ft (3.0 m) with VP 6.0 receptacle	1 lb (0.5 kg)	Add 1 lb (0.5 kg)
23747-03	Interconnecting cable 50 ft (15.2 m) with VP 6.0 receptacle	3 lb (1.5 kg)	Add 1 lb (0.5 kg)

ENGINEERING SPECIFICATIONS

Engineering Specification for 400 and 400VP sensor (Cell constants 0.01, 0.1, and 1.0/cm)

1. The sensor shall be suitable for the determination of electrolytic conductivity in clean, non-corrosive samples.
2. The sensor shall have a 3/4- inch MNPT fitting for direct insertion into pipes or tees. A clear plastic flow cell shall also be available for side-stream samples.
3. The sensor shall incorporate titanium electrodes and a PEEK insulator.
4. The sensor shall have an integral platinum RTD for temperature measurement.
5. The sensor shall be available with either integral cable or a Variopool quick disconnect fitting.
6. The maximum temperature for the sensor shall be 221°F (105°C) at 250 psig (1825 kPa abs). A high temperature option that can be used at 392°F (200°C) shall also be available.
7. The sensor shall be suitable for vacuum service as low as 7.4 psia (51 kPa abs).
8. The sensor shall be Rosemount Analytical Model 400 (integral cable) or 400VP (Variopool fitting) or approved equal.

Engineering Specification for 402 and 402VP sensor (Cell constants 0.01, 0.1, and 1.0/cm)

1. The sensor shall be suitable for the determination of electrolytic conductivity in clean, non-corrosive samples where the ability to remove the sensor from the process piping or tank without shutting down or draining lines or equipment is desired.
2. The sensor shall be supplied with a retraction assembly and full port ball valve. The ball valve shall be connected to the piping or tank using a 1-1/4 inch close nipple.
3. The sensor shall incorporate titanium electrodes and a PEEK insulator.
4. The sensor shall have an integral platinum RTD for temperature measurement.
5. The sensor insertion tube shall be 316 stainless steel.

6. The ball valve shall be 316 stainless steel with Teflon seals and seats.
7. The retraction body shall be 316 stainless steel and shall use three graphite packing rings to seal the sensor tube.
8. The maximum temperature for the sensor shall be 212°F (100°C) at 200 psig (1481 kPa abs).
9. The maximum retraction pressure shall be 64 psig (542 kPa abs).
10. The sensor shall be available with integral cable, integral junction box, or a Variopool quick disconnect fitting.
11. The sensor shall be Rosemount Analytical Model 402 (integral cable) or 402VP (Variopool fitting) or approved equal.

Engineering Specification for 404 Sensor (0.01 and 0.1/cm cell constants)

1. The sensor shall be suitable for the determination of electrolytic conductivity in clean, non-corrosive sidestream samples where rapid response to changes in conductivity or temperature is needed.
2. The sensor shall incorporate titanium electrodes and a PEEK insulator.
3. The sensor shall have an integral platinum RTD for temperature measurement.
4. The sensor shall be available with either a PVC or stainless steel body flow cell
5. The PVC body sensor shall have 3/8-inch barbed tubing connectors.
6. The stainless steel body sensor shall have compression fittings for 3/8-inch OD tubing. The compression fittings shall be removable to leave 1/4-inch FNPT ports.
7. The maximum temperature for the PVC body sensor shall be 140°F (60°C) at 20 psig (239 kPa abs).
8. The maximum temperature for the stainless steel body sensor shall be 212°F (100°C) at 100 psig (791 kPa abs).
9. The sensor shall be Rosemount Analytical Model 404 or approved equal.

COMPATIBLE ANALYZERS AND TRANSMITTERS

The Model 1055 Dual Input Analyzers offer the choice of single or dual sensor input with measurement choices of pH/ORP, resistivity/conductivity/ TDS, % concentration, ratio conductivity, total and free chlorine, dissolved oxygen, dissolved ozone, flow and temperature. Dual measurement analyzers offer a wide choice of measurement combinations thus reducing the cost per loop and needed panel space.



The Model 54eC Conductivity Analyzer and an Endurance Conductivity Sensor can be used to monitor and control conductivity in a variety of industrial processes. The Model 54eC features an easy-to-use interface which spells out each operation with fully descriptive messages. The analyzer, housed in a robust NEMA 4X enclosure, also features two independent outputs for conductivity and temperature and three process alarms with programmable logic.



The Model 5081 Conductivity Transmitter and an Endurance Conductivity Sensor can be used to monitor conductivity or resistivity in a variety of processes. The Model 5081 uses state-of-the-art micro-processor technology. Two digital communication protocols are available: HART and Foundation Fieldbus. Digital communications allows access to AMS (Asset Management Solutions). Use AMS to set up and configure the transmitter, read process variables, and troubleshoot problems from a personal computer or host anywhere in the plant. A handheld infrared remote controller or the HART Model 275 communicator can also be used for programming and calibrating the transmitter. The remote controller works from as far away as six feet. The user-friendly menus of the Model 5081 (Calibrate/Program/Diagnose), coupled with descriptive headers and prompts, almost eliminate the need for an instruction manual.



The Solu Comp Model Xmt-C Conductivity Transmitter can be used with most ENDURANCE conductivity sensors. The transmitter has a two-line display. Menu screens for calibrating and configuring are simple and intuitive. Plain language prompts guide the user through the procedures. Two digital communication protocols are available: HART (model option -HT) and FOUNDATION fieldbus (model option -FF). Digital communications allow access to AMS (Asset Management Solutions). Use AMS to set up and configure the transmitter, read process variables, and troubleshoot problems from a personal computer or host anywhere in the plant. The keypad allows local programming and calibrating of the transmitter. The HART Model 375 communicator can also be used for programming and calibrating the transmitter.



Other Compatible Instruments include the following models: Solu Comp, 54C, 1054C, 1054AC, 1054BC, 1054BDC, 1054BLC, 1054BR, 81C, 1181C, 2081C, 3081C, and 4081C.



*The right people,
the right answers,
right now.*

ROSEMOUNT ANALYTICAL
CUSTOMER SUPPORT CENTER
1-800-854-8257

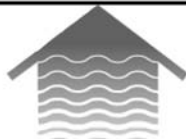

ON-LINE ORDERING NOW AVAILABLE ON OUR WEB SITE
<http://www.raihome.com>

Specifications subject to change without notice.



Credit Cards for U.S. Purchases Only.



Emerson Process Management

Liquid Division

2400 Barranca Parkway
Irvine, CA 92606 USA
Tel: (949) 757-8500
Fax: (949) 474-7250

<http://www.raihome.com>